



Duplex Pump Down Controller with High Alarm

PDC

Operation

The PDC has been designed to operate as an alternating Duplex Pump Down Controller with high alarm. The PDC also has the capability of sensing one or two damaged float switches and adjusting its operation accordingly.

When the level rises above the "Cut-Off" float, the input closes to the PDC, the LED is illuminated, but no pump outputs are initiated. As the level continues to rise above the "Lead" float, the LED is illuminated and the output contact to start pump #1 is closed. If the level begins to lower below the "Lead" float, the "Lead" float LED goes out, but pump #1 continues to run until the "Cut-Off" float opens. This is the end of a pumping cycle.

Since a pumping cycle has been completed, the PDC will automatically switch the lead pump to pump #2 (Alternating Operation). This provides for distributed running time on both pumps, helps to ensure that the impellers are cleared periodically and the seals are wetted, extending the life of the pump.

Next time the "Lead" float closes, the pump #2 comes on first. If the level continues to rise and the "Lag" float is closed, then pump #1's output contacts will be closed too. Both pumps will be running at this time. As the level clears the "Lag" and "Lead" floats, the appropriate LEDs will go out, but both pumps continue to run until the "Cut-Off" float is cleared. This ends the pumping cycle and the lead and lag positions of the pumps switches again.

To avoid pulsing the pump motors On and Off due to turbulence in the tank, when a "Lead" or "Lag" float switch closes, it latches in until the "Cut-Off" float opens. If both "Lead" and "Lag" float switches are closed when power is applied to the PDC, there will be a 5 sec. time delay to start the first pump and another 5 sec. delay to start the second pump. This avoids high inrush levels during recovery from a power outage.

Specifications

Electrical

Line Voltage:
24V AC/DC, ±10%
115 or 230VAC, ±10%, 1Ø, 50/60Hz
Inputs: Normally Open (NO) contact
or Solid State (NPN)

Power Up Delay: 5 Sec., Fixed
Second Pump Delay: 5 Sec., Fixed
Contact Ratings:
10 Amps Total Unit Rating
5 Amps @ 240VAC, per contact
10 Amps @ 120VAC, per contact
100,000 Full Load Electrical Cycles
10,000,000 Mechanical Cycles

Physical

Mounting: Surface
Termination: Screw Terminals Removable (Plug-In)
Packaging: Dust Cover
Weight: 2 Lbs. Approx.

Ambient Temperatures

Operating: 0°C to 65°C
Storage: -30°C to 85°C

Dimensions

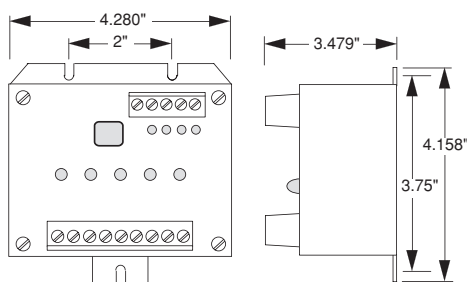

Ordering Information

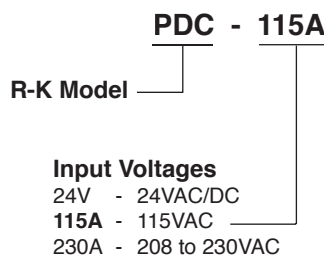

- Pump Down
- De-Bounced Inputs
- High Alarm Output
- Lost Input Compensation
- Removable Terminal Blocks
- Low Level Cut-Off
- Staggered Starting
- Indicating LEDs
- Manual or Auto Alarm Reset
- Float Sequence Error Alarm



Connections

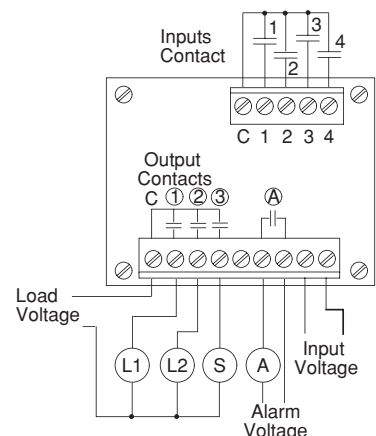

Normal Operation:

When the level rises above the “Cut-Off” float, the input closes to the PDC, the Cut-Off LED is illuminated, but no pump outputs are initiated. As the level continues to rise above the “Lead” float, the Lead LED is illuminated and the output contact to start pump #1 is closed. As the level begins to lower below the “Lead” float, the “Lead” float LED goes out, but pump #1 continues to run until the “Cut-Off” float opens. This is the end of a pumping cycle.

Next time the “Lead” float closes, pump #2 comes on first.

If the level rises above both the Lead and Lag float switches, both pumps will run until the Cut-Off float switch opens.

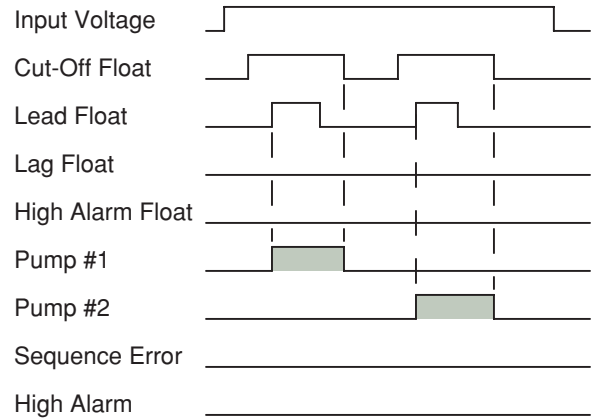

Lost Cut-Off Float Operation:

In this operation as the level rises it passes where the Cut-Off float switch would be activated, but the PDC does not receive that signal. Either a bad float switch or no float switch. As the level continues to rise, the Lead Float switch is activated. The PDC recognizes the error is sequence and activates the Sequence Error Alarm and the Lead float switch operates as the “Cut-Off” float switch. As the level continues to rise and activates the Lag float switch, the first pump in the sequence is turned on. Pump down continues until the Lead float switch is open which will de-energize the pump(s) output.

The High Alarm float now acts as the Lag float switch to activate the second pump and as the High Alarm.

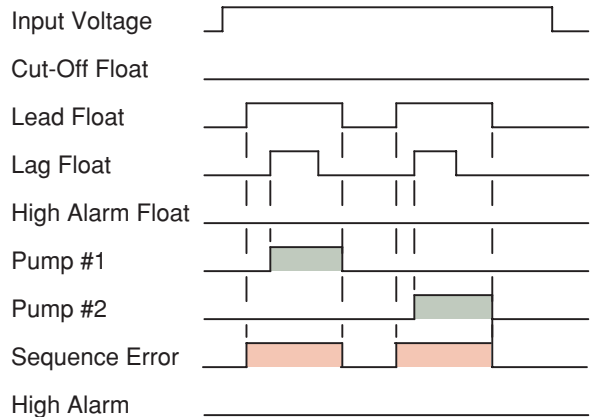

High Alarm Operation:

When the level rises above the “Cut-Off” float, the input closes to the PDC, the Cut-Off LED is illuminated, but no pump outputs are initiated. As the level continues to rise above the “Lead” float, the Lead LED is illuminated and the output contact to start pump #1 is closed. As the level continues to rise and the Lag float switch is closed Pump #2 will be activated.

If the level continues to rise, the High Alarm will be activated. At that time the Alarm Output will be activated and both pumps will continue to run.

As the level begins to lower below the High Alarm, Lag and then the Lead float switches, the appropriate LEDs will go out, but both pumps will continue to run until the “Cut-Off” float opens.

If the High Alarm is set for “automatic” reset. when the Cut-Off float switch opens the High Alarm output will de-energize.

If the High Alarm is set for “manual” reset. when the Cut-Off float switch opens the High Alarm output will remain energized until the reset switch is operated or power is removed from the PDC.

